

Determination of sugars and natural sugar substitutes in different matrices

Juliane Böttcher, Hagen Schlicke, Kate Monks; applications@knauer.net KNAUER
Wissenschaftliche Geräte GmbH, Hegauer Weg 38, 14163 Berlin; www.knauer.net



SUMMARY

Nowadays sugar substitutes are used in many products, not only for diabetic purposes but to make products more attractive for customers. Furthermore, people are interested in a healthier lifestyle which includes consuming less sugar. Therefore, a quality control of sugar and sugar substitutes in food and beverages needs to be compulsory, to assure the correct composition of ingredients.

INTRODUCTION

Sweet taste is favored by human beings. People instinctively desire the pleasure of sweetness, which resulted in a preference for sweet foods and beverages [1]. But sugar is rich in calories and that is why a lot of people are switching to light products containing sugar substitutes. These products contain less calories and are often obtained from natural crude materials, e.g. wood fibers of the birch. This application will focus

on the determination of commonly used sugars and natural sugar substitutes. Sucralose (E 955) is a high-intensity sweetener, about 600 times higher than saccharose. Mannitol (E 421) and sorbitol (E 420) have about half the intensity of saccharose and xylitol (E 967) has a quite equal intensity as commonly used sugar [2].

Determination of sugars and natural sugar substitutes in different matrices

RESULTS

A mixed standard of saccharose, sucralose, glucose, fructose, mannitol, xylitol, and sorbitol was used for calibration in a range from 0.25 mg/mL up to 2.0 mg/mL. Five different samples of caffeinated soft drinks as well as one sample of chewing gum and one sample of tooth paste were analyzed. Various compositions and contents of the analytes in the samples were determined (Tab A1, additional results).

Fig 1 shows a chromatogram of sample 5 compared to the standard mix. It reveals that this sample contains saccharose, glucose, and fructose exclusively. The analyzed chewing gum and tooth paste contain only mannitol, xylitol, and sorbitol. Additional peaks were observed in both chromatograms but are not related to the substances in the standard mix (Fig 2 & 3).

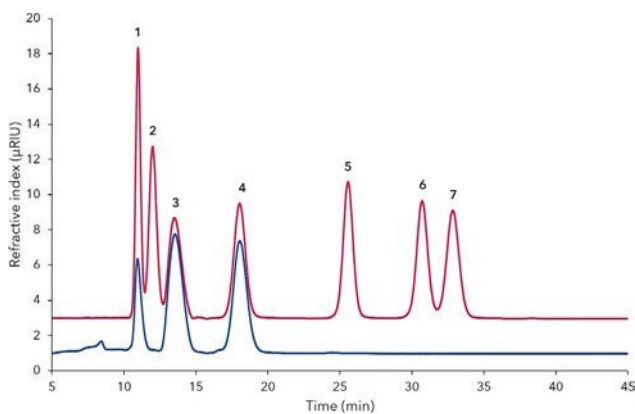

Fig. 1 Overlay of mixed standard (red) and Guarana soft drink with sugar (dilution 1:30, blue), 1) saccharose, 2) sucralose, 3) glucose, 4) fructose, 5) mannitol, 6) xylitol, 7) sorbitol

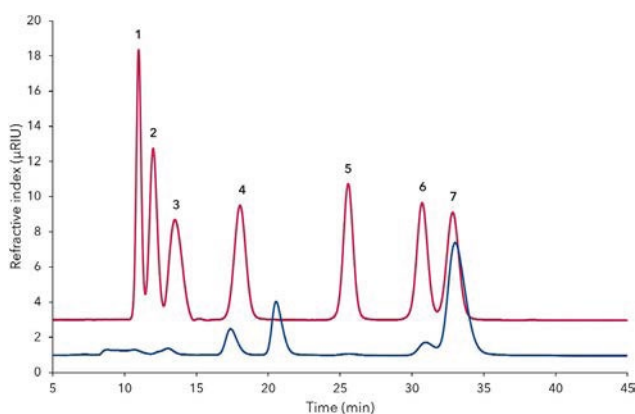

Fig. 2 Overlay of mixed standard (red) and extracted tooth paste (blue), 1) saccharose, 2) sucralose, 3) glucose, 4) fructose, 5) mannitol, 6) xylitol, 7) sorbitol

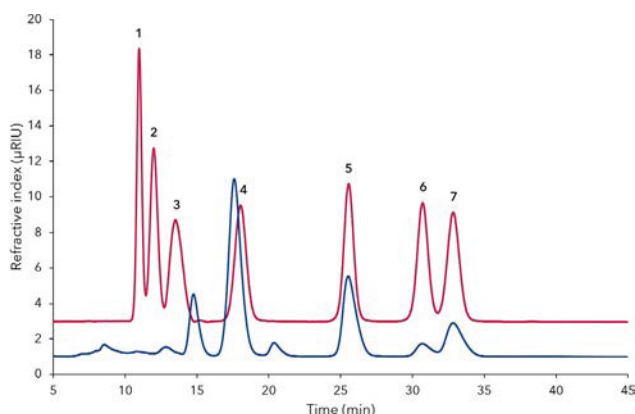

Fig. 3 Overlay of mixed standard (red) and extracted chewing gum (blue), 1) saccharose, 2) sucralose, 3) glucose, 4) fructose, 5) mannitol, 6) xylitol, 7) sorbitol

MATERIALS AND METHODS

The AZURA® dedicated system for sugar analytics with an additional autosampler was used for this application. The system consisted of an isocratic AZURA P 6. 1L pump, an AZURA autosampler AS 6.1L, an AZURA CT 2.1 column thermostat, an AZURA RID 2.1L refractive index detector and an Eurokat Ca column in a dimension 300 x 8 mm ID with precolumn 30 x 8 mm ID filled with the same material. Eurokat Ca is a sulfonated cross-linked styrene-divinylbenzene copolymer. The isocratic method ran 45 minutes at a flow rate of 0.5 mL/min with 100 % aqueous eluent. The column thermostat was set to 60 °C and the data rate of the detector to 20 Hz. 20 µL of samples and standards were injected.

CONCLUSION

The presence of natural sugar substitutes besides sugars in the same sample matrix is not prevalent but quite feasible. It can be seen, that the caffeinated soft drinks only contained sugar and no sugar substitutes. As expected the soft drinks which were declared to be "light" had no measurable amount of sugars. The extracted tooth paste and chewing gum were specified to be sugar-free but contain sugar substitutes. The detection of mannitol, xylitol or sorbitol was as expected. With the described method it is possible to identify the most commonly used sugars and natural sugar substitutes in one run. With little effort in sample preparation it is even contingent to determine these substances from solid samples such as chewing gum or tooth paste.

REFERENCES

- [1] <https://www.ncbi.nlm.nih.gov/pmc/articles/PMC3098376/>
- [2] <https://www.bzfe.de/inhalt/kennzeichnung-von-zusatzstoffen-1881.html>

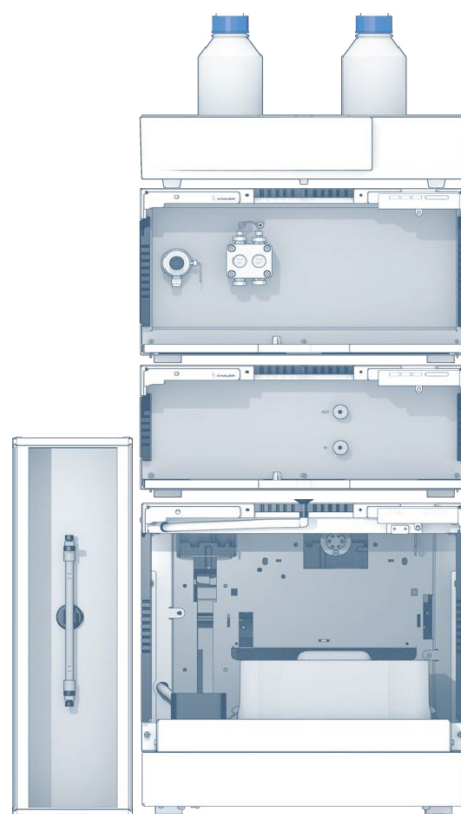

ADDITIONAL RESULTS

Tab.A1 Results of sample measurements (n.d. = not detectable)

Peak	Substance	Sample 1 (with sugar) in mg/mL	Sample 2 (light) in mg/mL	Sample 3 (light) in mg/mL	Sample 4 (Bio, with sugar) in mg/mL	Sample 5 (Guarana with sugar) in mg/mL	Sample 6 (chewing gum) in g/100 g	Sample 7 (tooth paste) in g/100 g
1	Saccharose	47.84	n.d.	n.d.	n.d.	8.54	n.d.	n.d.
2	Sucralose	n.d.	n.d.	n.d.	n.d.	n.d.	n.d.	n.d.
3	Glucose	17.12	n.d.	n.d.	37.58	30.60	n.d.	n.d.
4	Fructose	15.60	n.d.	n.d.	34.82	26.52	n.d.	n.d.
5	Mannitol	n.d.	n.d.	n.d.	n.d.	n.d.	10.98	0.23
6	Xylitol	n.d.	n.d.	n.d.	n.d.	n.d.	5.84	2.11
7	Sorbitol	n.d.	n.d.	n.d.	n.d.	n.d.	5.84	19.71

ADDITIONAL MATERIALS AND METHODS

Tab.A2 Method parameters

Eluent	Water		
Gradient	isocratic		
Flow rate	0.5 mL/min	System pressure	ca. 35 bar
Column temperature	60 °C	Run time	45 min
Injection volume	20 µL	Injection mode	Full loop
Detection	RI	Data rate	20 Hz
		Time constant	0.05 s

Tab.A3 System configuration

Instrument	Description	Article No.
Pump	AZURA P6.1L, isocratic	APH30EA
Autosampler	AZURA AS 6.1L	AAA00AA
Detector	AZURA RID 2.1L	ADD31
Thermostat	AZURA CT 2.1	A05852
Column	Vertex Plus Column, 300 x 8 mm, Eurokat Ca, 10 µm	30GX360EKN
	Vertex Plus Column, 30 x 8 mm, Eurokat Ca, 10 µm	03GX360EKN
Software	ClarityChrom 7.2	A1670-11



Dedicated AZURA® Sugar Analytical System

RELATED KNAUER APPLICATIONS

VFD0161 - Determination of sugars in honey using HILIC separation and RI detection

VFD0155 - Semi preparative xylitol purification with dedicated sugar purification system

VFD0150 - Alternative xylitol extraction via hplc purification from fermented biomass

VSP0013 - Simplified scale up for sugars with the AZURA RID 2.1L extended dynamic range option